



Henderson County Government
Request for Proposals for Compost Collection Building

Date of Issue: April 4, 2023

Proposal Due Date: April 18, 2023, at 3:00PM EST

Direct all inquiries concerning this RFP to:

Doug Guffey

Purchasing Agent

Phone: 828-694-5023

Email: hcpurchasing@hendersoncountync.gov

BID PROPOSAL FORM

Pursuant to the General Statutes of North Carolina **informal bids**, subject to the conditions and specifications herein, are invited for the construction of a compost collection building. Bids may be submitted via email to hcpurchasing@hendersoncountync.gov or via mail to the Henderson County Finance Department, at 113 North Main St., Hendersonville, NC 28792. Bids will be due on April 18, 2023, at 3:00PM EST.

The undersigned, as bidder, hereby declares that this proposal is made without connection with any other person, company, or parties making a similar bid or proposal, and that the proposal is in all respects fair and in good faith, without collusion or fraud.

The bidder has carefully examined the annexed form of specifications and instructions to bidders and hereby declares that they will construct a compost collection building in the manner prescribed in the specifications and instructions to bidders for the following price:

DESCRIPTION	EXTENDED PRICE
Compost Collection Building	

GRAND TOTAL FOR ALL GOODS AND SERVICES. INCLUSIVE OF SHIPPING TO HENDERSON COUNTY, NORTH CAROLINA AND INSTALLTION	
--	--

PLEASE NOTE BID PRICES AND SPECIFICATIONS SHALL BE FULLY ENFORCEABLE FOR 120 DAYS AFTER THE BID DUE DATE UNLESS NOTED BELOW:

Printed Name of Firm Representative: _____

Signature of Firm Representative: _____

Title: _____

Name of Firm Submitting Proposal: _____

Firm Address: _____

Telephone Number: _____

Email Address: _____

BIDDER'S CHECKLIST

- Be aware of the bid opening and date and time as indicated on the first page of this proposal.
- All signatures must be by a company officer or agent who is authorized to enter into, and sign bid documents.
- Have you read and understood the "Terms and Conditions" and the "Instructions to Bidders" for submitting a bid?
- Have you read, and do you completely understand all the specifications of this bid proposal?
- If an addendum to the specifications was issued, has it been signed and returned with this bid proposal?
- Have you enclosed statements explaining any exceptions made to the specifications?
- Have you included executed copies of the attachments?
- Have you included copies of the appropriate licensure as defined by the bid documents?
- Have you included a proposed contract inclusive of the County terms and conditions?
- Have you included a Certificate of Insurance with minimum limits provided herein naming Henderson County as additionally insured?

Section 1: Purpose

The purpose of this document is to provide general and specific information for the construction of a compost collection building. All bids and contracts are governed by Henderson County policy and Section 143-131 of the North Carolina General Statutes.

Section 2: Bid Schedule

Listed below are the dates and times by which stated actions must be taken or completed. The County may determine, in its sole discretion, that it is necessary to change any of these dates and times. Should changes be required, proper notice will be provided to potential bidders. All listed times are Eastern standard times.

Action	Time	Date
Bid issued	5:00 PM	April 4, 2023
Deadline for Questions	5:00 PM	April 11, 2023
County Responses	5:00 PM	April 13, 2023
Bids Due	3:00 PM	April 18, 2023

Section 3: Bid Contact

All questions, concerns and requests for additional information shall be directed to the Henderson County Purchasing to the attention of Doug Guffey, Purchasing Agent

Doug Guffey
hcpurchasing@hendersoncountync.gov

Section 4: Bidder Questions

The County is not liable for interpretations/misinterpretations or other errors, or omissions made by the Bidder in responding to this bid. The Bidder shall examine this bid to determine if the County’s requirements and terms and conditions are clearly stated. If, after examination of the various requirements and terms and conditions of this bid, the Bidder believes there are any requirements or terms and conditions which remain unclear or which restrict competition, the Bidder may request, in writing, that the County clarify the requirement(s) and terms(s) and condition(s) specified by the Bidder. The Bidder must provide the Section(s), Subsection(s), Paragraph(s), and page number(s) that identify the requirements or conditions questioned by the Bidder.

Requests for clarification and technical questions to this bid must be received by the County no later than the date shown above in Section 2, entitled “Bid Schedule”, under Deadline for Questions. The Bidders’ failure to request clarification and submit questions by the date in the bid schedule above shall be considered to constitute the Bidders’ acceptance of all County requirements and terms and conditions. The County shall issue addenda reflecting questions and answers to this bid, if any, and shall be posted to the County’s website at <https://www.hendersoncountync.gov/rfps>.

Section 5: Objections to the Specifications

It is not the intent of the bid specifications to exclude or limit competition or favor any supplier. If there is an objection to any of the specifications or requirements listed herein, the bidder must notify Doug Guffey, Purchasing Agent in writing, stating, and listing the specifications and objections, no later than the date shown above in Section 2, entitled "Bid Schedule", under Deadline for Questions. If a pre-bid meeting has been scheduled, any objections must be presented in writing at that time. The objections stated must pertain both to form and substance of the bid document. Failure to object in accordance with the above procedure shall constitute a waiver on the part of the bidder to protest the solicitation. All concerns, questions, clarifications, or other correspondence must be directed only to Doug Guffey, Purchasing Agent. Information obtained from other sources will not be considered in the evaluation and award of this bid.

Section 6: Alternate Bids

Alternate bids are allowed. Alternate bids are those that are not identical by manufacturer and model to what is outlined within the bid document or one which has substantially different specifications to what is outlined in the bid document. When alternate bids are submitted, the bidder must submit documentation for review as a part of the bid to show that the product meets or exceeds the specifications of the item(s) referenced in the specifications. It shall be the responsibility of the bidder to show that the alternate equipment is equivalent and conforms to the specifications contained herein. Bidders may submit multiple bids on various manufacturers' brands/models.

Section 7: Bid Options

The County reserves the right to request pricing on optional equipment or services along with the pricing for the main or primary product or items when applicable. At the discretion of the County, some or all of the options requested may or may not be added and purchased based upon necessity and the availability of budgeted funds. The bid award will be made to the lowest, responsive, responsible bidder for the main or primary product or services on the Bid Proposal Form. Pricing for any additional options will be requested in a separate section of the bid and will not be included in the determination of the bid award.

Section 8: How to Prepare Bid Proposals

Bidders are encouraged to carefully review all provisions and attachments of this document prior to completion. Each bid constitutes an offer and may not be withdrawn except as provided herein. Also, prices are to remain firm for the period stated herein.

- a) **PROPOSAL FORM:** Submit all prices and offers on the **BID PROPOSAL FORM(s)** provided herein. All bid proposals must be submitted and signed by the supplier or their authorized representative with all erasures or corrections initialed and dated by the authorized representative of the proposal.
- b) **Addendum(s):** If applicable, bidders shall include signed addendum(s) with their bid submittal acknowledging the modifications made to the bid document.

- c) **SIGNATURE: All bids must be signed by an authorized official of the company on the Bidders Signature Page.** A bid may be rejected if it shows omissions, alterations of form, additions not called for, conditional bid, or any irregularities.
- d) **TAXES: Do not include taxes in your bid prices.** Taxes must be itemized and added to invoices separately when invoicing the County. The County is required to pay sales tax. The County is exempt from Federal Excise Tax and has a Federal Tax number.

Section 9: How to Submit Bid Proposals

- a. **SUBMIT BIDS ON THE BID PROPOSAL FORM PROVIDED HEREIN.**
- b. Bids may be submitted via email to hcpurchasing@hendersoncountync.gov
- c. Bids may be mailed or delivered as follows:

Mailing & Delivery Address:

RFP: Compost Collection Building
Henderson County Finance Department
113 N. Main St.
Hendersonville, NC 28792

- d. Please note bids not received by the time and date specified on the Bid Proposal Form will not be opened or considered.
- e. Bidders shall provide any available product literature and manufacturer's specifications at the request of Henderson County.

Section 10: Bid Opening

- a. All bids will be opened at the time and place shown on the enclosed Bid Proposal Form. **LATE BIDS WILL NOT BE OPENED OR ACCEPTED.**
- b. Bids will be examined by the Purchasing Agent and the using department officials promptly after the opening and an award made as early as possible.
- c. Bidders may request and receive copies of the bid documents and/or bid tabulation after the award of the project.

Section 11: Award of Bid

- a. **Standard of Bid Award Acceptance:**
The County reserves the right to reject any and/or all bids received as allowed by law, or to select the bid which, in our opinion, is in the best overall interest of the County. The award shall be made to the lowest, responsive, responsible bidder, or bidders, taking into consideration quality, performance and the time specified in the bid for the performance of the contract.

b. **Bid Prices:**

All items and products proposed in response to this Bid are to be new, in un-used condition unless otherwise noted in the minimum specifications. All prices proposed in response to this Bid are to include all transport, freight, fuel surcharges and other fees if applicable and be delivered **FOB destination, freight prepaid and allowed** to the construction location unless otherwise specified in the specifications section. All items are to be packaged, and shipped or delivered safely in a protective carton, fully assembled and serviced, ready for use and operation where applicable or otherwise described within the specifications. All supplies, equipment, and apparatus must meet all Federal, State, and Local safety regulations, requirements, and guidelines, such as OSHA, EPA, US DOT, NC-DOT, NFPA, UL, etc., if so regulated.

c. **Order of Precedence:**

In cases of conflict between sections and provisions within the Bid document, the Order of Precedence will be 1) the Special Conditions section specific to the Bid (if present); 2) the Minimum Specifications section specific to the Bid, 3) Henderson County Terms and Conditions; and 4) the Instructions to Bidders section of the Bid document.

Section 12: Errors in Bids & Bid Withdrawal

Bidders or their authorized representatives are expected to understand the conditions, requirements, and specifications before submitting bids. Failure to do so will be at the bidders' own risk. In case of an error in the extension of prices on the bid, the unit price shall govern.

Section 13: Bid Tabulation

Pursuant to North Carolina General Statute 143-131(a), bidders may request a bid tabulation from the Purchasing Agent, after the contract has been awarded.

Section 14: Specifications

I. Overview:

It is the intent of these specifications to set up minimum requirements for the construction of a compost collection building as specified. These specifications must be considered as minimum requirements. If it is necessary to bid alternate equipment or to take exceptions to the specifications as set forth, this must be so stated in your bid. Any reference to a model or brand is only to denote quality and does not mean that equal equipment will not be considered.

II. Specifications

1. Please see Attachment I for engineered drawings.
2. Shall be responsible for final grade.

III. Installation

1. Bidder shall provide a turnkey project inclusive of all labor, materials, supervision, disposal fees, permits, inspections for the construction of a compost collections building.
2. Install all materials and equipment in accordance with manufacturer's instructions and warranty requirements.
3. Contractor must submit a timeline for the beginning and completion of the project.

4. Contractor is to obtain and pay for any and all required permits and inspections. Any deficiencies found in the installation or materials used in the installation which prevents receiving a green tag from inspectors or issues found during the final walkthrough with County representatives will be the Contractors responsibility and expense to correct.
5. Cleanup of all affected work areas shall be completed daily.

IV. Warranty

1. The installation services and materials furnished by the contractor, or any subcontractors shall be free from any defects in workmanship for a period of one year from the date of final payment.

V. Acceptance of Work

1. Bidder shall perform a final walk through with a County representative upon completion.
2. Henderson County shall receive all inspections, certifications, and permits required by local and State agencies as applicable. Henderson County is to receive written copies of all.
3. Henderson County shall receive all warranties, maintenance manuals, product data, and closeout documents as applicable.

Section 15: Licensure

Bidder shall provide a copy of their general contractor licensure. If not provided the bid will be considered nonresponsive.

Section 16: Minority and Disadvantaged Business

Pursuant to General Statutes of North Carolina Sections 143-128 and 143-131 as well as 2 CFR 200.321 of the Uniform Administrative Requirements, the County encourages and provides equal opportunity for Certified Minority and Women- Owned Business Enterprise (MWBE) businesses to participate in all aspects of the County's contracting and procurement programs.

For Disadvantaged Business Enterprise requirements, see Minority Business Participation Guidelines posted under Doing Business with Henderson County at

https://www.hendersoncountync.gov/sites/default/files/fileattachments/henderson_county/page/42611/00092588.pdf

Section 17: Contracting

Bidder shall include a proposed contract signed by the bidder and ready for county signature. The contract shall include at minimum the following language:

- i. Section 20 Grant Terms and Conditions
- ii. Section 21 County Terms and Conditions
- iii. Section 22 Certificate of Insurance

Section 18: Grant Terms & Conditions

Any proposal submitted to Henderson County shall be deemed to include all the Grant Terms and Conditions as follows:

- I. **Compliance with Laws:** The bidder shall comply with all laws, ordinances, codes, rules, regulations, and licensing requirements that are applicable to the conduct of its business, including those of federal, State, and local agencies having jurisdiction and/or authority.

- II. **Equal Employment Opportunity:** The bidder shall take affirmative action in complying with all federal and State statutes and all applicable requirements concerning fair employment of people with disabilities and concerning the treatment of all employees without regard to discrimination by reason of race, color, religion, sex, national origin or disability. For additional information see Title VI of the Civil Rights Act of 1964 (42 U.S.C., 2000d, 2000e- 16), Title XI of the Education amendments of 1972, as amended (20 U.S.C. 1681-1683 and 1685-1686), and section 504 of the Rehabilitation Act of 1973 as amended (29 U.S.C. 794).

- III. **Executive Order 24:** In accordance with Executive Order 24, issued by Governor Perdue, and N.C.G.S. § 133-32, a vendor or contractor (i.e. architect, bidder, contractor, construction manager, design professional, engineer, landlord, offerer, seller, subcontractor, supplier, vendor, or grantee), is prohibited from making gifts or giving favors to any employee of the Agency of Agriculture and Consumer Services. This prohibition covers those vendors, contractors, and/or grantees who:
 - (a) have a Contract with a governmental Agency; or
 - (b) have performed under such a Contract within the past year; or
 - (c) anticipate bidding on such a Contract in the future.

For additional information regarding the specific requirements and exemptions, vendors, contractors, and/or grantees are encouraged to review Executive Order 24 and N.C.G.S. § 133-32.

- IV. **Access to Persons and Records:** The State Auditor and the County’s internal auditors shall have access to persons and records as a result of all Contracts or grants entered into by State agencies or political subdivisions in accordance with General Statute 147-64.7 and Session Law 2010-194, Section 21 (i.e., the State Auditors and internal auditors may audit the records of the contractor during the term of the Contract to verify accounts and data affecting fees or performance).

- V. **Amendment:** This Contract may not be amended orally or by performance. Any amendment must be made in written form and executed by duly authorized representatives of the bidder and the County.

- VI. **Advertising:** The bidder shall not use the award of this Contract as a part of any news release or commercial advertising.

Section 19: County Terms and Conditions

Any proposal submitted to Henderson County shall be deemed to include all the Terms and Conditions shown in the document found online at

https://www.hendersoncountync.gov/sites/default/files/fileattachments/henderson_county/page/42611/purchase_order_terms_and_conditions_rev_03-26-2019.pdf

These Terms and Conditions, which refer to a “purchase order”, shall be deemed to be included in any agreement entered as a result of this RFP.

Any attempt by a proposed contracting party under the RFP to exclude any of these Terms and Conditions shall cause any Proposal made in response to this RFP to be deemed to be non-responsive (unless Henderson County has notified the firm that the funding source for the goods or work sought under this RFP is not federal funds, in which case those provisions under number 15 of the Terms and Conditions (and all subparts thereunder) may be excluded from a Proposal.

Section 20: Insurance Requirements

The Bidder shall provide an Insurance Certificate naming Henderson County as **additionally insured** per the attached certificate of insurance. Should different insurance limits be established between the vendor and the County, the Certificate of Insurance with Henderson County named as additional insured shall be contained herein.

Required Coverage	Minimum Insurance Limits
Workers' Compensation	Statutory/Employers Liability: \$1M/\$1M/\$1M
General Liability	\$1M per occurrence/\$1M aggregate - Per Project basis
Automobile	\$1M Combined Single Limit
Excess Liability	\$2M per occurrence
Builder's Risk	Amount of contract for above ground construction

Section 21: Funding Source

This RFP is funded with **State Funds** via the North Carolina Department of Environmental Quality. 2 CFR Part 200 Federal Uniform Administrative Requirements, Cost Principles, and Audit are not applicable.

Section 22 Attachments

- Attachment I: Engineered Drawings
- Attachment II: Vendor Information Form



ADVANCED COMPOSTING TECHNOLOGIES

20' x 15' COLLECTION BUILDING PHASE II

- CAUTION -
BEFORE STARTING EXCAVATION
CHECK FOR UNDERGROUND UTILITIES

For: Henderson County
1 Historic Courthouse Square
Hendersonville, North Carolina 28792

P: 828.697.4809

Henderson County

Index

<u>Sheet Title</u>	<u>Sheet No.</u>
COMPOST FACILITY	
COVER SHEET -----	1
SITE PLAN AND SECTIONS -----	2
CONCRETE SLAB PLAN -----	3
KNEE WALL DETAILS AND AIR PIPING -----	4
BUILDING SECTIONS AND DETAILS -----	5
BUILDING SECTION AND ELEVATION -----	6
CONSTRUCTION NOTES & CERTIFICATION STATEMENTS -----	7

No.	Revisions	Date	By
1	Issued For Review	02/11/22	RSW
2	Issued For Construction	04/18/22	RSW
3	Revised - Rotated Bldgs / Pads To Fit Site	05/17/22	RSW
4	Issued For Review	05/17/22	RSW
5	Re-Issued For Review	02/06/23	RSW
6	Re-Issued For Construction	02/20/23	RSW
7	Removed Approach Pad (Back) & Re-Issued For Construction	03/27/23	RSW

REVISIONS			
NO.	DESCRIPTION	DATE	BY

APPROVALS			
PROJECT ENG:	DESIGNED BY:	DRAWN BY:	CHECKED BY:
RSW	RSW	CKD	RSW

--	--	--	--

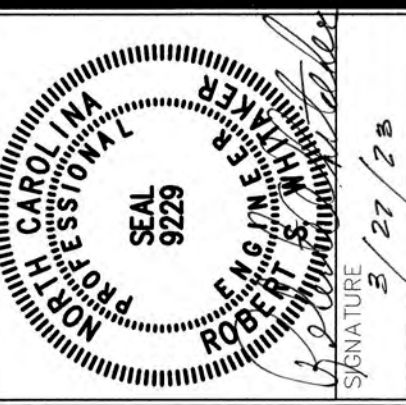

SHEET TITLE	COVER SHEET
DATE: MAR. 2022	SCALE: AS SHOWN

PROJECT	ADVANCED COMPOSTING TECHNOLOGIES
P.O. Box 2440	Candler, North Carolina 28715
20'x15' COLLECTION BUILDING	HENDERSON COUNTY

N.B. NO.	SHEET
REF.	1
PROJECT NO.	OF
05530	7

THIS DRAWING WAS PREPARED FOR ADVANCED COMPOSTING TECHNOLOGIES. ANY REPRODUCTION OR OTHER USE OF THIS DOCUMENT WITHOUT EXPRESS WRITTEN CONSENT OF ADVANCED COMPOSTING TECHNOLOGIES IS PROHIBITED.

FILE: HendersonCounty-CollBlid

THIS DRAWING WAS PREPARED FOR ADVANCED COMPOSTING TECHNOLOGIES. ANY REPRODUCTION OR OTHER USE OF THIS DOCUMENT WITHOUT EXPRESS WRITTEN CONSENT OF ADVANCED COMPOSTING TECHNOLOGIES IS PROHIBITED.

REVISIONS	
NO.	DESCRIPTION

APPROVALS	
PROJECT ENG:	DATE BY
RSW	
DESIGNED BY:	
RSW	
DRAWN BY:	
CKD	
CHECKED BY:	
RSW	
APPROVED:	
RSW	

PROJECT INFORMATION	
PROJECT NO.	DATE
05530	3/27/2023

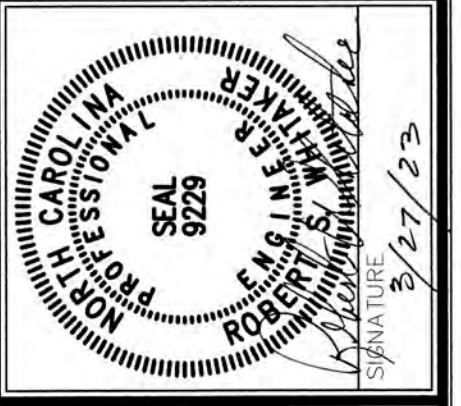

Advanced Composting Technologies

KNEE WALL DETAILS AND AIR PIPING

DATE: MAR. 2022 SCALE: AS SHOWN

ADVANCED COMPOSTING TECHNOLOGIES
P.O. Box 2440
Candler, North Carolina 28715

20'x15' COLLECTION BUILDING
HENDERSON COUNTY

N.B. NO.	SHEET
REF.	4
PROJECT NO.	OF
05530	7
FILE: HendersonCounty-CollBldg	

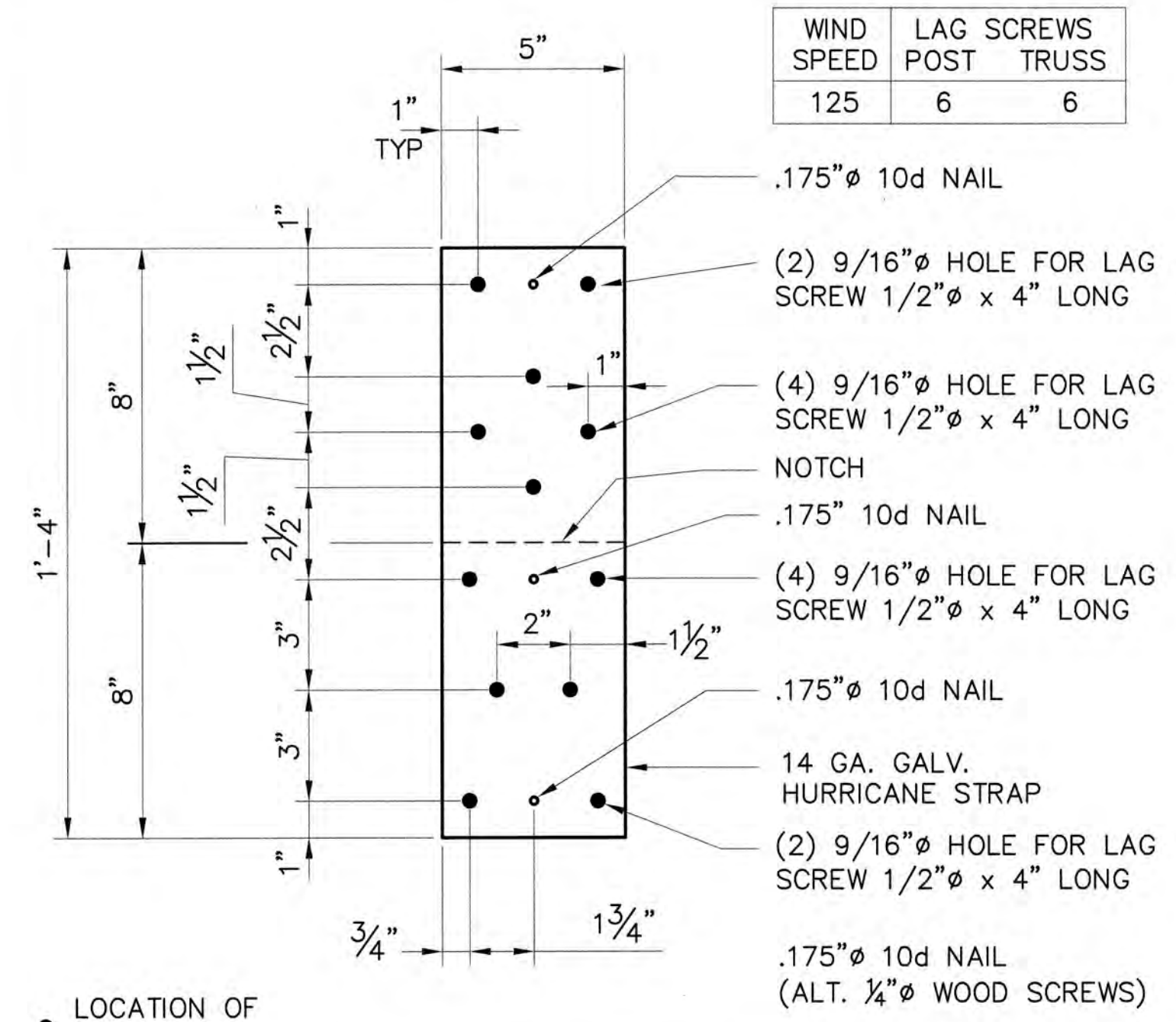

HURRICANE STRAP DETAIL
3" = 1'-0"

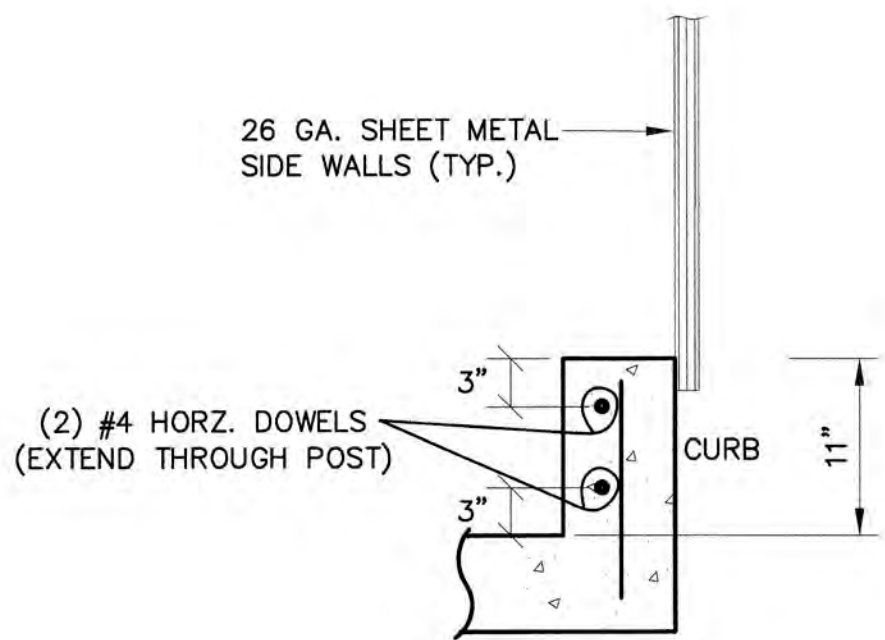

SIDE WALL SINGLE WALL CURB DETAIL
1" = 1'-0"

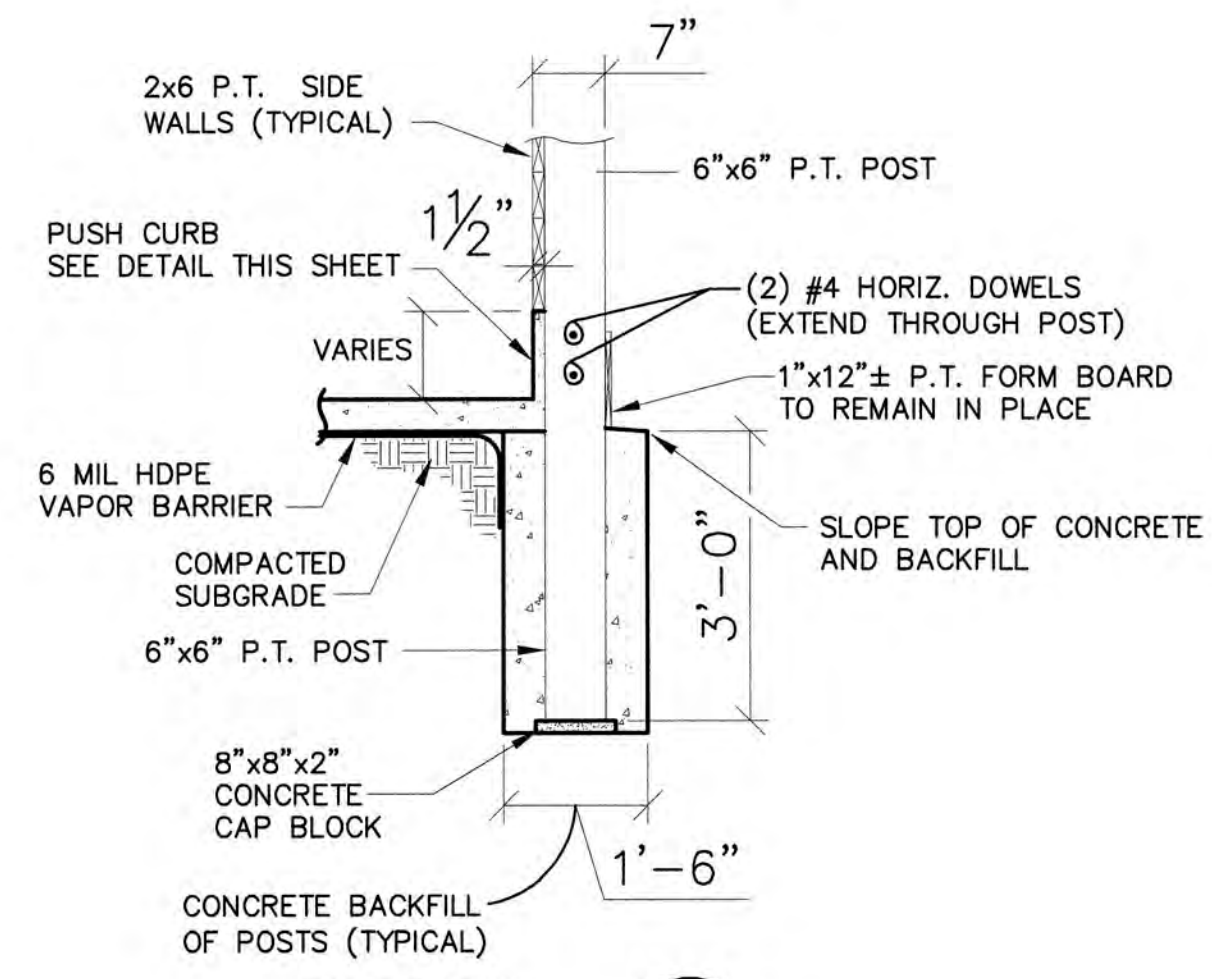

SECTION C
1/2" = 1'-0"

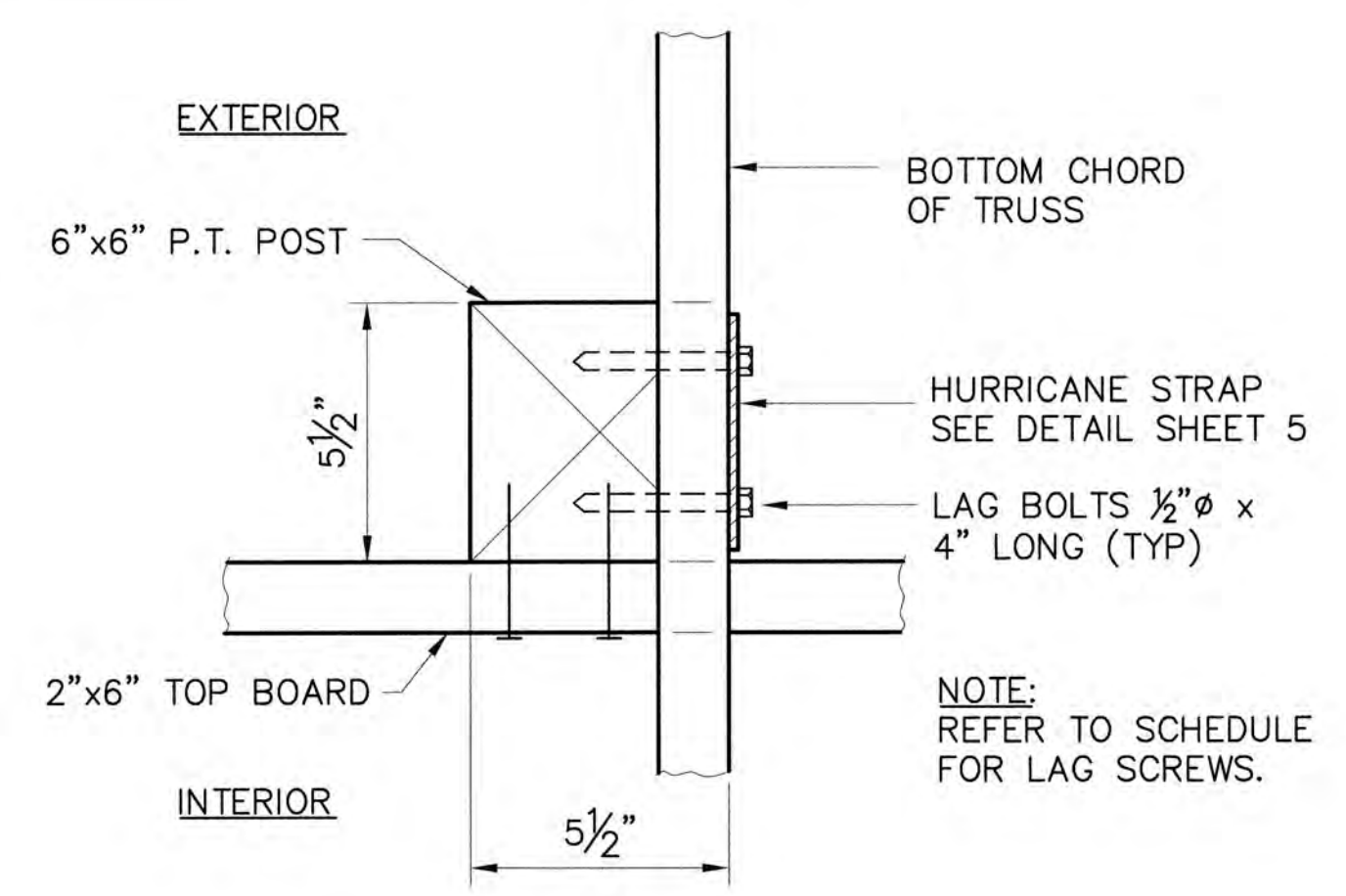

PLAN

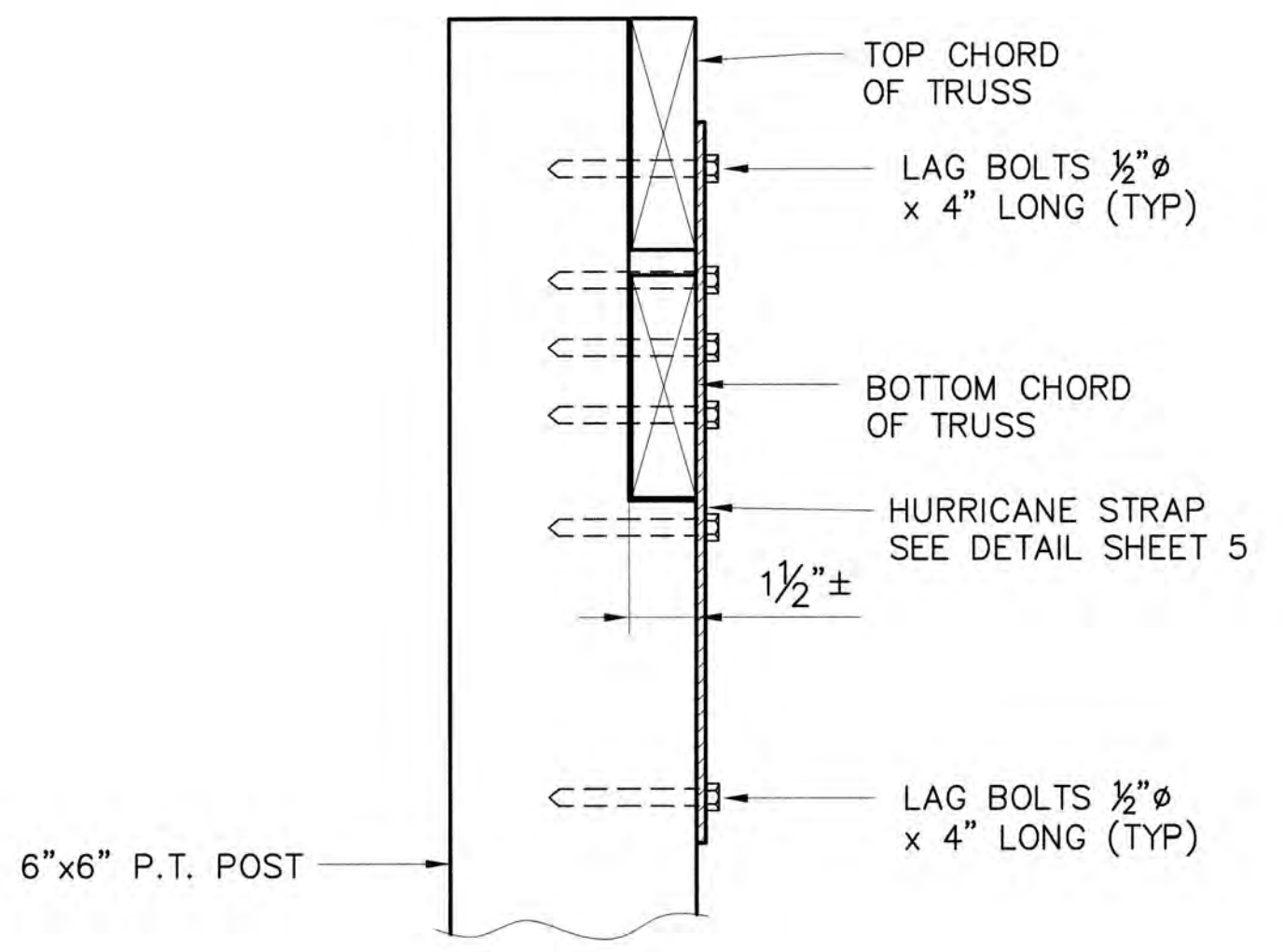

SECTION

POST / TRUSS CONNECTION SECTION E
NOT TO SCALE

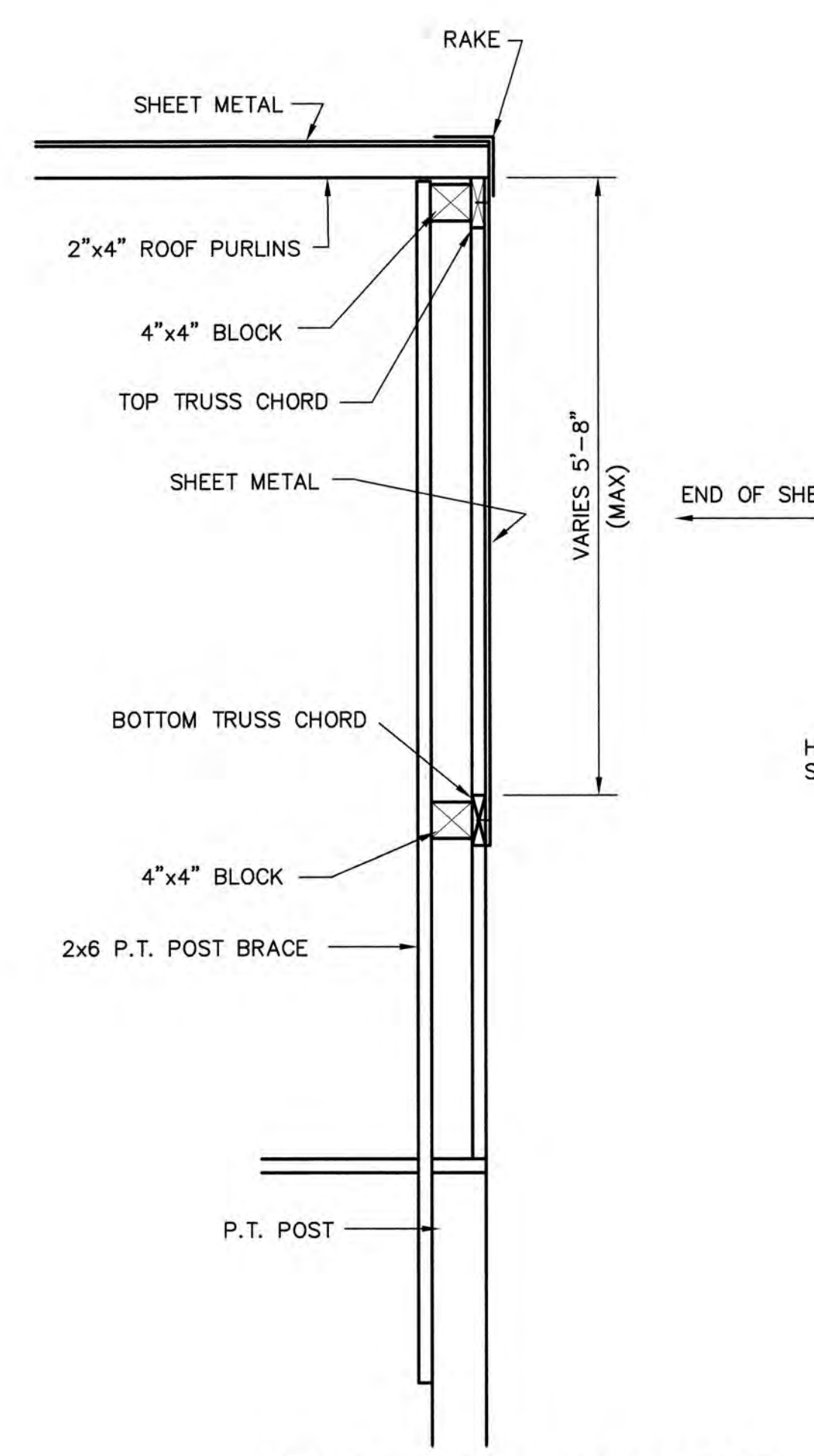

TYPICAL GABLE END DETAIL
3/4" = 1'-0"

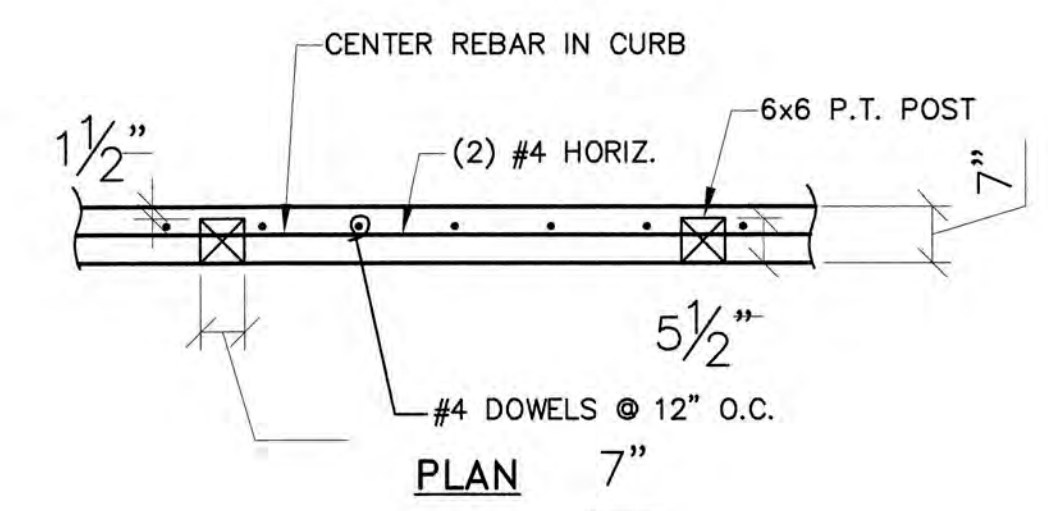

PLAN

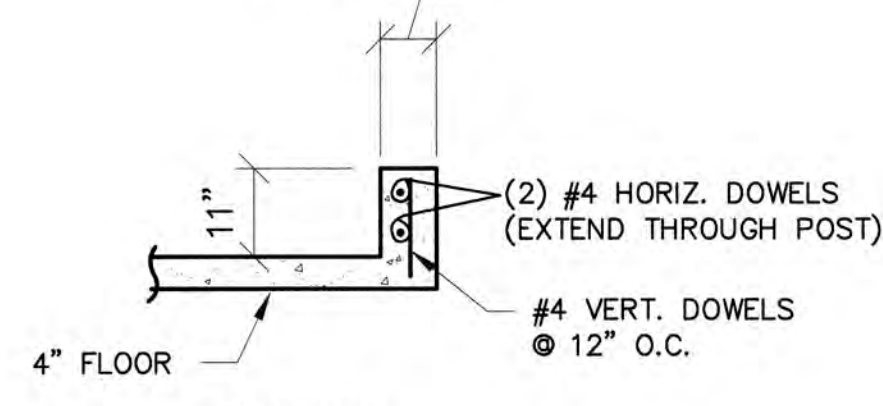

SECTION

PUSH CURB FOR 6x6 POSTS DETAIL

DETAIL D
1/2" = 1'-0"

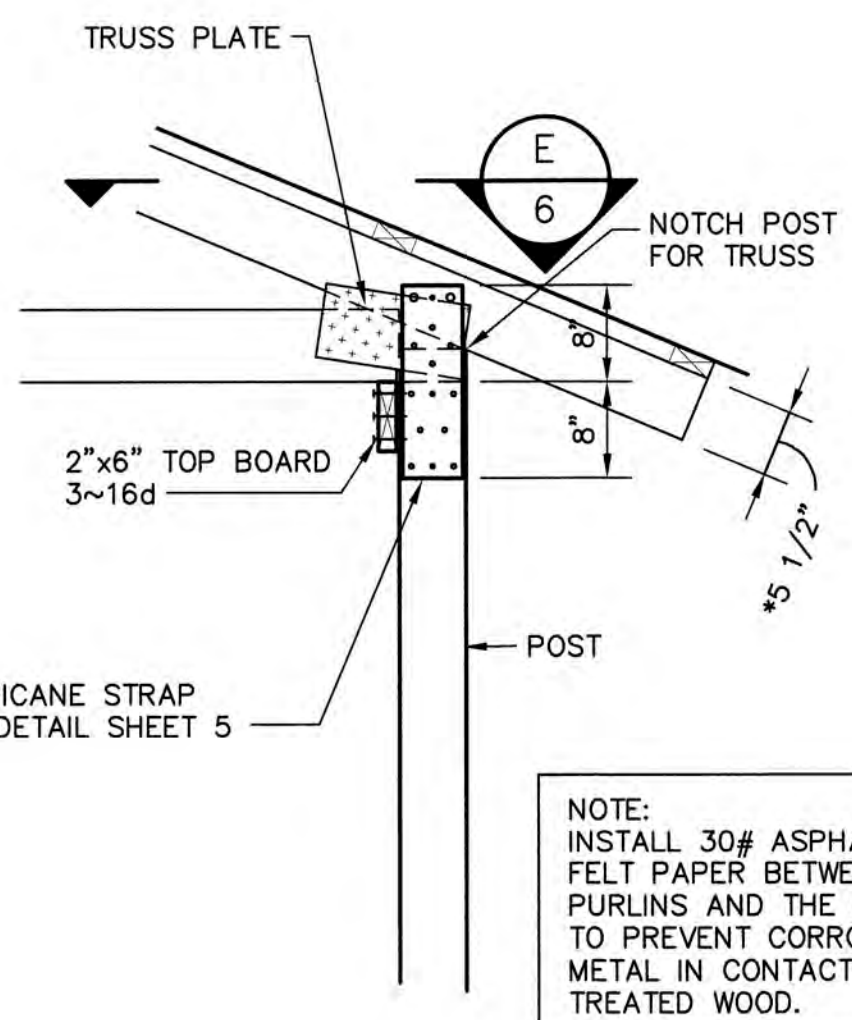

NOTE: INSTALL 30# ASPHALT IMPREGNATED FELT PAPER BETWEEN THE 2x4 PURLINS AND THE METAL SHEETING TO PREVENT CORROSION OF THE METAL IN CONTACT WITH THE TREATED WOOD.

* - DEPENDS ON SIZE OF TRUSS TOP CHORD
DETAIL 1
3/4" = 1'-0"

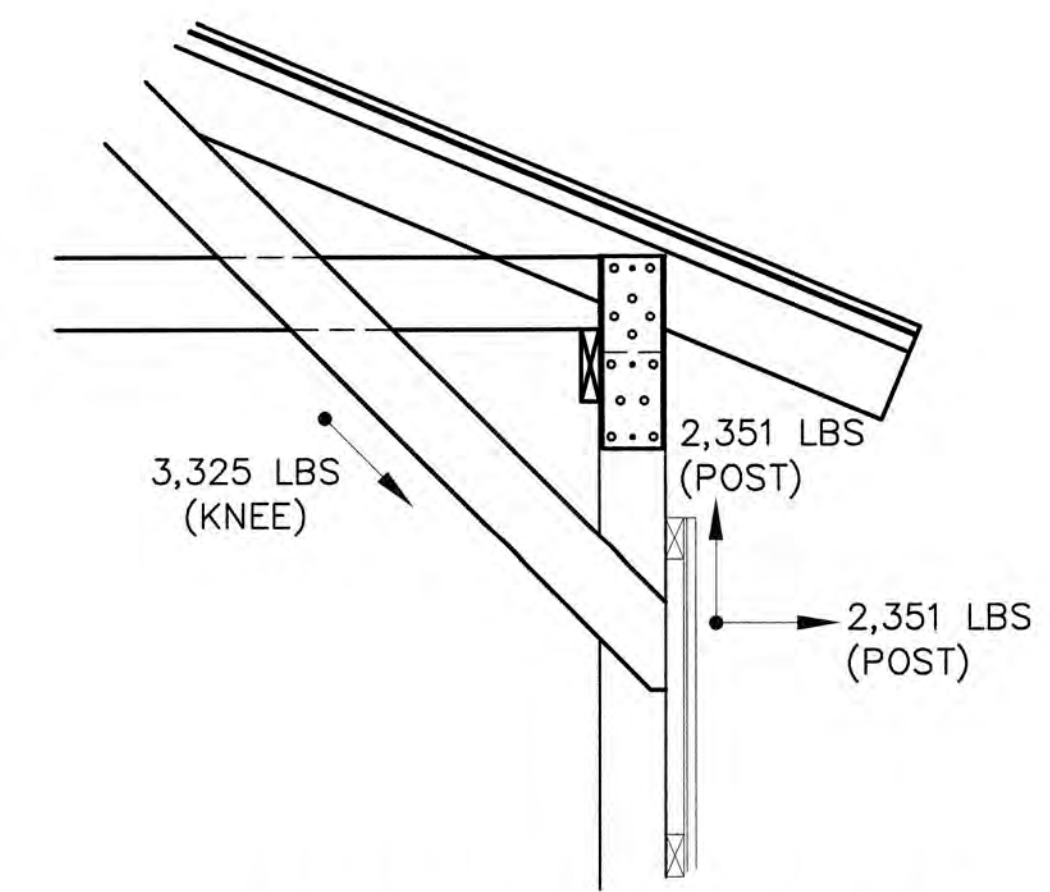

KNEE BRACE FORCES
SCALE: NOT TO SCALE

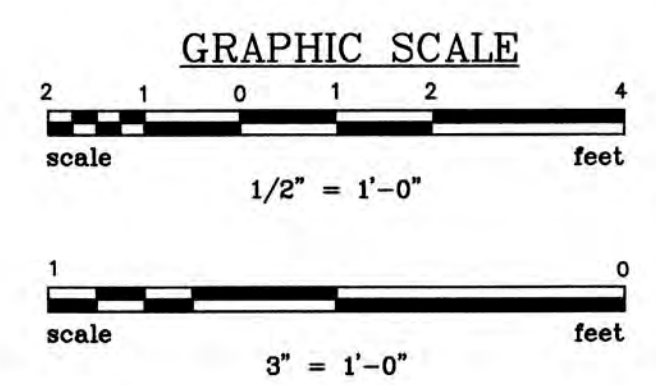

N:\PROJECTS\05530.DWG\HENDERSONCOUNTY-COLLECTIONBLDG-HENDERSONCOUNTY-COLLBIDG.DWG 3/27/2023 3:12:25 PM

THIS DRAWING WAS PREPARED FOR ADVANCED COMPOSTING TECHNOLOGIES. ANY REPRODUCTION OR OTHER USE OF THIS DOCUMENT WITHOUT EXPRESS WRITTEN CONSENT OF ADVANCED COMPOSTING TECHNOLOGIES IS PROHIBITED.

NO.	DESCRIPTION	DATE	BY

PROJECT ENG.	DESIGNED BY	DRAWN BY	CHECKED BY	APPROVED BY
RSW	RSW	CKD	RSW	RSW

--	--	--	--	--

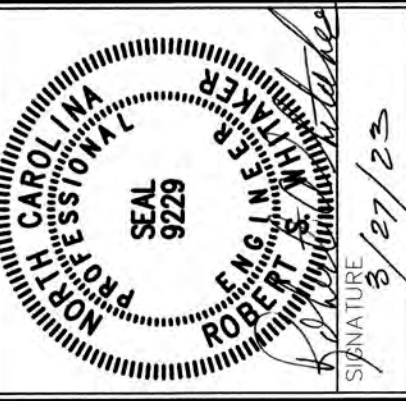

BUILDING SECTION AND ELEVATION
 SHEET TITLE
 DATE: MAR. 2022 SCALE: AS SHOWN

PROJECT
ADVANCED COMPOSTING TECHNOLOGIES
 P.O. Box 2440
 Candler, North Carolina 28715
20'x15' COLLECTION BUILDING
 HENDERSON COUNTY

N.B. NO.	SHEET
REF.	6
PROJECT NO.	OF
05530	7

FILE: HendersonCounty-CollBldg

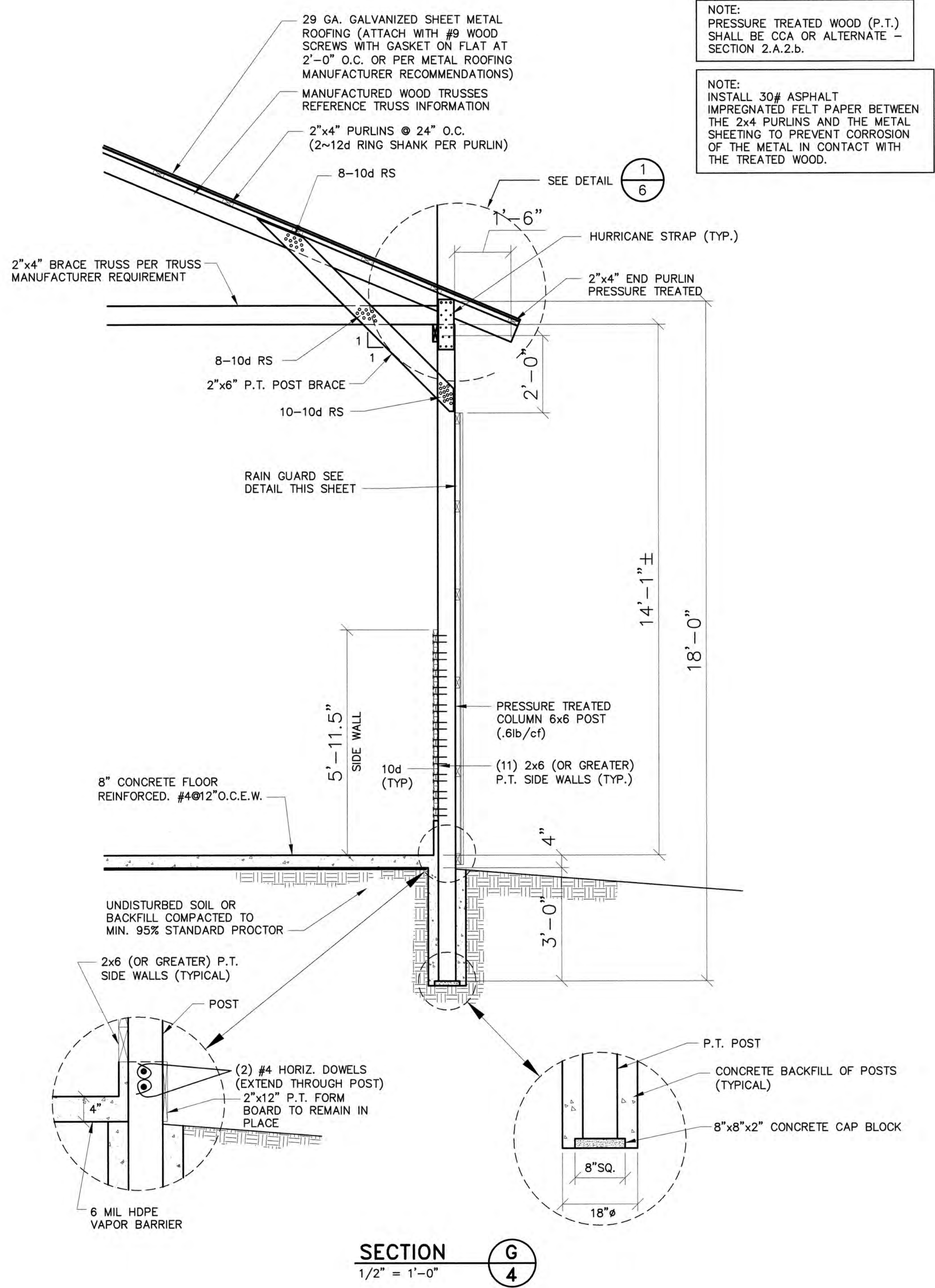

NOTE:
 PRESSURE TREATED WOOD (P.T.) SHALL BE CCA OR ALTERNATE - SECTION 2.A.2.b.

NOTE:
 INSTALL 30# ASPHALT IMPREGNATED FELT PAPER BETWEEN THE 2x4 PURLINS AND THE METAL SHEETING TO PREVENT CORROSION OF THE METAL IN CONTACT WITH THE TREATED WOOD.

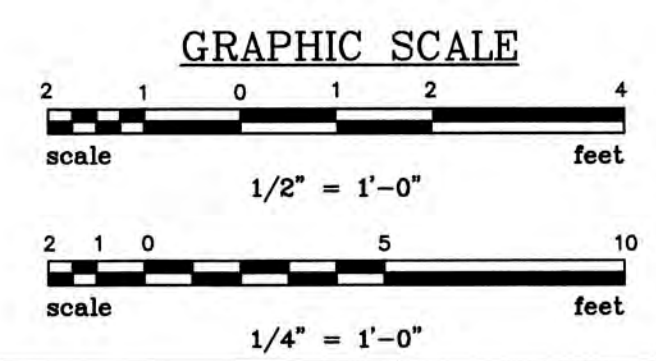
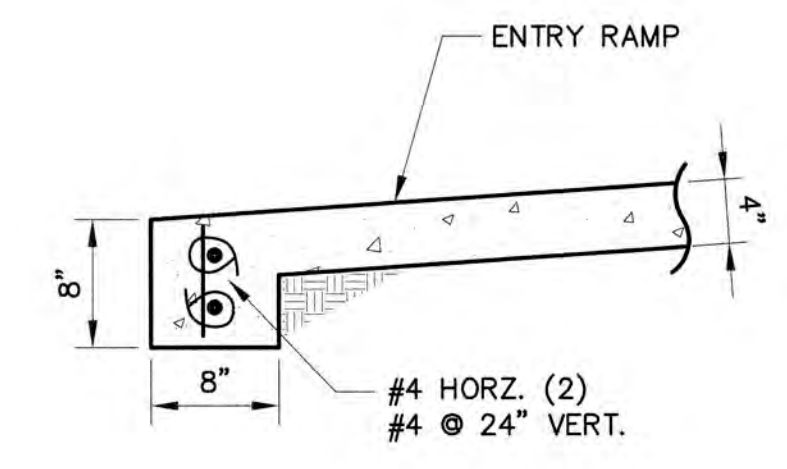
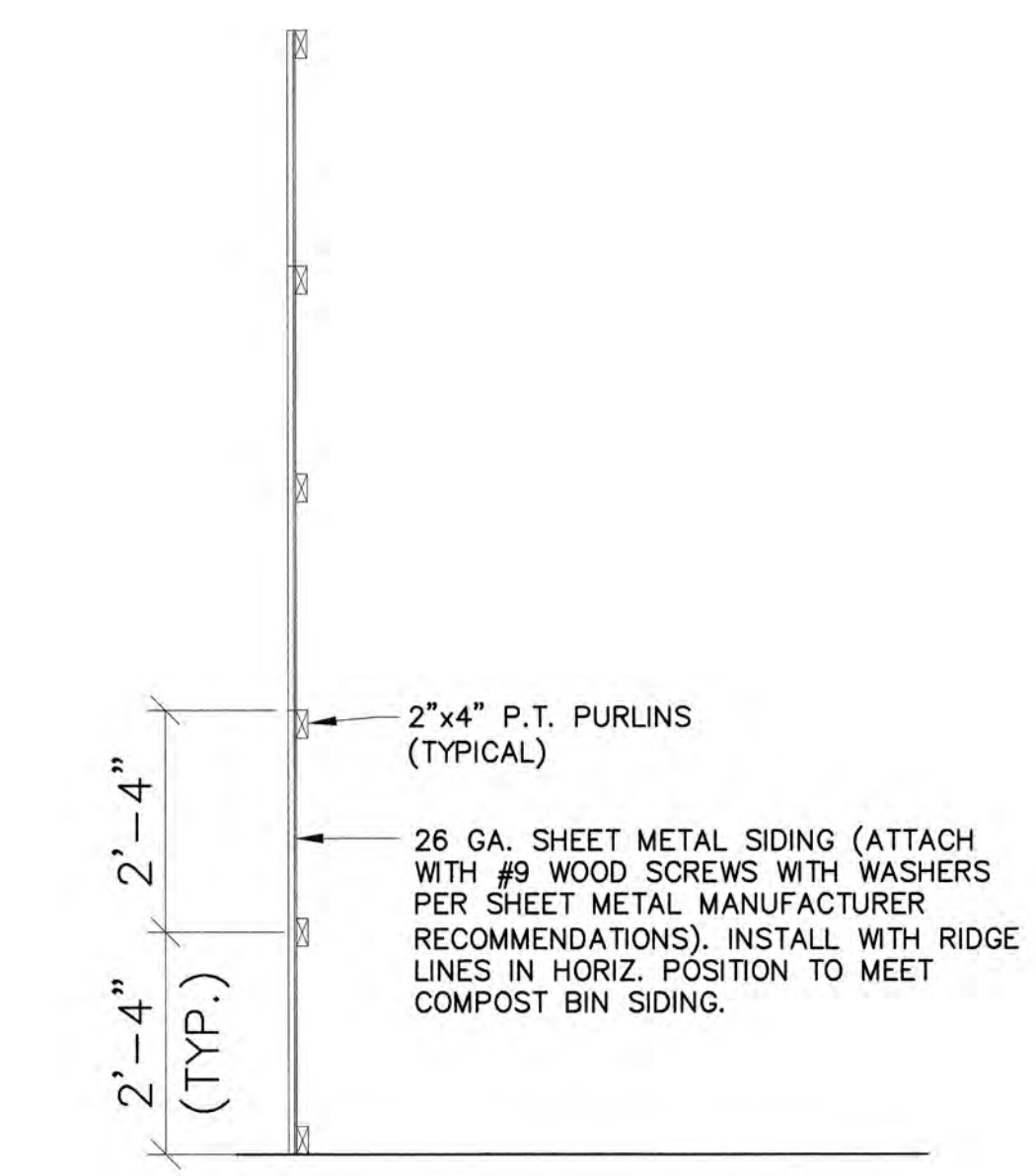

N:\PROJECTS\05530\DWG\HENDERSONCOUNTY-COLLECTIONBLDG-G-HENDERSONCOUNTY-COLLBLDG.DWG_3/27/2023 3:17:42 PM

CONSTRUCTION NOTES

SECTION 1 – GRADING

Clearing

- A. The site shall be cleared of all vegetation, grass, roots, and debris. The topsoil shall be removed to residual and clay/silt or sandy soil subgrade.

Grading

- A. The Owner shall be responsible for all site grading, stabilization and proper compaction.
- B. The site shall be shaped to the size of the compost facility and graded to drain away from the facility.
- C. The site shall be graded to residual soil and any soft or unstable subgrade excavated, backfilled and compacted.
- D. Sites on fill shall be uniformly graded, backfilled, and compacted to 95% Standard Proctor using heavy grading equipment or roller compactor.
- E. The site shall be proof rolled by driving a loaded truck or other heavy rubber tired equipment over the site and inspected for movement or "pumping of the soil". If movement is observed, the soft areas are to be excavated, backfilled and recompacted.
- F. All finished subgrade shall have a minimum bearing strength of 2000 lb/sf.

SECTION 2 – MATERIALS

- A. All lumber shall be of good quality southern yellow pine (SYP) No. 2 or better.
 - 1. Structural members shall be manufactured to meet the loads, spacing, and spans as noted on the drawings.
 - a. Wind loads shall meet the local codes of each county where the facility is located as noted on the drawings.
 - 2. Rafters may be a manufactured wood product with equal or greater strength than SYP No 2.
 - a. Pressure treated lumber (PT) shall be preserved with copper chromated arsenic (CCA-Type I, II, or III) conforming to Federal Specification TT-W-571.
 - 1. The following wood components of the facility are to be pressure treated.
 - a. Rear Post columns on walls – 0.4 lb. retention
Rear Post columns in ground – 0.6 lb. retention
 - b. Front post columns on walls – 0.4 lb retention
Front post columns in ground – 0.6 lb retention
CCA – 0.60 lb/cf, ACQ – 0.60 lb/cf
 - c. Exposed boards and purlins as noted on the drawings – 0.4 lb. retention
 - d. Column bracing – 0.4 lb retention
 - b. Alternative copper pressure treated lumber (PT) shall be preserved in accordance with American Wood Preservative Association (APWA) Standard UC4B and commodity standard C15/C16.
 - 1. Under these standards the following preservatives are allowed.
 - a. Post Columns
 - 1) ACQ – 0.40 lb/cf
 - 2) CBA-A – 0.41 lb/cf
 - 3) ACZA – 0.40 lb/cf
 - b. Exposed boards and purlins
 - 1) ACQ – 0.40 lb/cf
 - 2) CBA-A – 0.40 lb/cf
 - 3) CZA – 0.40 lb/cf
 - 4) MICRONIZED CQC – 0.34 lb/cf (GROUND CONTACT)
 - 5) MICRONIZED CAC – 0.15 lb/cf (GROUND CONTACT)
 - c. Column Bracing
 - 1) ACQ – 0.40 lb/cf
 - 2) CBA-A – 0.40 lb/cf
 - 3) CZA – 0.40 lb/cf
 - 4) MICRONIZED CAC – 0.15 lb/cf
 - 2. The alternative copper preservatives are corrosive to metal. All metal surfaces in direct contact with the pressure treated lumber shall be in accordance with section 2, B with minimum 30 lb. felt.
 - 3. All pressure treated lumber shall be accredited by the American Lumber Standard Committee (ALSC) and shall conform to the standards of the AWP.
 - a. When alternative treated lumber is used, the end tag shall be saved and made available to the NRCS for their review as part of the cost reimbursement program.
 - 3. The following wood components of the facility do not need to be pressure treated.
 - a. Roof rafters
 - b. Roof purlins
- B. Aluminum fasteners shall not be used in direct contact with treated wood. Galvanized or stainless steel bolts, washers, nuts, nails and other hardware which meet requirements of ASTM A153 for fasteners and A653 Class G185 sheet metal for connections, type 304 or 316 stainless steel, or other type of coating as approved by the preservative manufacturer. All fasteners, connectors and other metal contacting ACZA, ACQ, or CA treated wood shall be stainless steel.
 - 1. Nails used to fasten pressure treated lumber shall be ring shank with annular threads or spiral shank nails, sized as shown on the drawings.
 - 2. Nails used to fasten purlins to the roof rafters shall be ring or spiral shank.
 - 3. Fasteners used to fasten sheet metal roofing, end walls and rain guard to purlins shall be #9 wood screws with washers.
 - 4. Bolts in contact with treated lumber shall be hot dipped galvanized or stainless steel.

- C. Roof decking shall be 29 gauge (ASTM A653, Grade 80, hot dipped G-90 galvanized steel) with raised seams.
- D. Fasteners, nails, wood screws, lag screws and bolts shall not be placed closer than 5 times the diameter of the fastener from the edge of the wood.
- E. All water stops between concrete walls and floors shall be minimum 6 inch PVC. overlap any water stop joints a minimum of 6 inches.

SECTION 3– CONCRETE

- A. Material – Concrete walls, floors and slabs on grade shall have a minimum compressive strength of 4,000 psi after 28 days.
 - 1. Cement shall be Portland cement, ASTM C 150 Type 1.
 - 2. Aggregate shall conform to:
 - a. Fine aggregate – ASTM C33
 - b. Coarse aggregate – ASTM C33 – Size #57
 - 3. Admixtures:
 - a. Air entrancing – ASTM C260
 - b. Calcium chloride is not allowed.
- B. Concrete Mix
 - 1. Maximum water cement ratio: .45/1
 - 2. Air entrainment: 4 – 6%
 - 3. Slump: 3–5 inches
- C. Floor reinforcement
 - 1. Bin floors and working slab reinforcement shall be grade 60 reinforcing bar.
- D. Footing and wall reinforcement shall be rebar, ASTM A615, grade 60.
- E. The finished concrete shall be prevented from drying for a curing period of at least 7 days after it is placed by either application of curing compound as recommended by the manufacturer or continuous moist curing or a combination of moist curing until curing compound is applied.

INSPECTION AND MAINTENANCE NOTES

- 1. Construction Inspection
 - A. Verify that lumber grade, preservative, and fasteners meet specification requirements.
 - B. Verify the sheet metal gauge, fasteners with washers and ridge cap.
 - C. Verify the facility dimensions, subgrade compaction, post & rafter spacing and connections.
 - D. Verify all nailed connections have the number and type of nails called for in the drawings.
 - E. Verify soil compaction and bearing strength from soils engineer report. Minimum compaction of fill is 95% Standard Proctor and minimum bearing strength of the subgrade is to be 2,000 lb/sf.
 - F. Verify concrete mix design. Concrete supplier to provide written mix design for 4,000 psi concrete at 28 days curing time.
 - G. Verify steel placement in footings and walls after forming and prior to pouring concrete.
 - H. Verify fastener sizes and materials.
- 2. Maintenance
 - A. Conduct regular, yearly, maintenance inspection and material repair or replacement for:
 - 1. Cracks and splits in wood posts and brace members.
 - 2. Any nail pull-outs at connections to rafters, bracing and roofing, side boards, etc.
 - 3. Cracks in concrete flooring outside the contraction joints. Repair by filling with concrete crack sealer.
 - 4. Excessively warped, rotted or sagging wood members.
 - 5. Roof leaks or loose sheet metal.
 - 6. Apply non-shrink Thoroseal over any vertical wall shrinkage cracks created by differential shrinkage between walls and floor slab.

Table 5C: End-Use-ICC Evaluation Service									
Southern Pine Preservatives and Retentions									
Code Official Advisory per International Code Council Evaluation Service Report (ESR)									
Classification	Preservative System	ESR	Use Category (UC & Minimum Retention Requirements - Pounds per Cubic Foot (pcf))						
			Above Ground			Ground Contact / Fresh Water			
			Interior	Fence	Decking	General Use	General Use	Critical	Piling
Waterborne, Copper Based, Solution	Alkaline Copper Quat (ACQ-C&D)	628	0.15	0.15	0.15	0.25	0.40	0.60	
		643	0.15	0.15	0.15	0.15	0.40	0.60	
		1980	0.20	0.15	0.15	0.20	0.40	0.60	
	Alkaline Copper Betaine (KDS)	2500	0.14	0.14	0.14	0.19	0.36		
	Alkaline Copper Betaine (KDS-B)	2500	0.10	0.10	0.10	0.14	0.27		
	Alkaline Copper + DCOI (ACD)	2711	0.13	0.13	0.13	0.17	0.28	0.44	
Waterborne, Copper Based, Suspension	Ammoniacal Copper Quat (ACQ-A&B)	1980	0.20	0.15	0.15	0.20	0.40	0.60	
	Copper Azole (CA-C)	1721	0.06	0.06	0.06	0.06	0.15	0.25	0.35
	Copper HDO Type A (CX-A)	1863	0.20	0.20	0.11	0.20	0.30	0.45	
	Dispersed Copper Azole (UCA-C)	1721	0.05	0.05	0.05	0.05	0.14	0.23	0.33
	Micronized Copper Azole (MCA)	2325	0.07	0.06	0.06	0.07	0.16	0.24	
Waterborne, Carbon Based	Micronized Copper Azole	2240	0.06	0.06	0.06	0.06	0.15	0.23	
	Micronized Copper Quat (MCQ)	1980	0.15	0.10	0.15	0.15	0.34	0.60	
	Tebuconazole + Imidacloprid (EL)	2067	0.0187	0.0187	0.0187	0.0187			
	DCOI + Imidacloprid (EL2)	1851	0.0187	0.0187	0.0187	0.0187			
Waterborne, Borates	Propiconazole-Tebuconazole-Imidacloprid (PTI)	1477	0.013	0.018	0.018	0.018	0.018		
	DOT & Polymer Binder	1081	0.50	0.50	0.50	0.50			
	Inorganiz Boron (SBX)	648	0.17						

THIS DRAWING WAS PREPARED FOR ADVANCED COMPOSTING TECHNOLOGIES. ANY REPRODUCTION OR OTHER USE OF THIS DOCUMENT WITHOUT EXPRESS WRITTEN CONSENT OF ADVANCED COMPOSTING TECHNOLOGIES IS PROHIBITED.

NO.	DESCRIPTION	DATE	BY

APPROVALS	PROJECT ENG.	DESIGNED BY:	DRAWN BY:	CHECKED BY:	APPROVED:

DATE

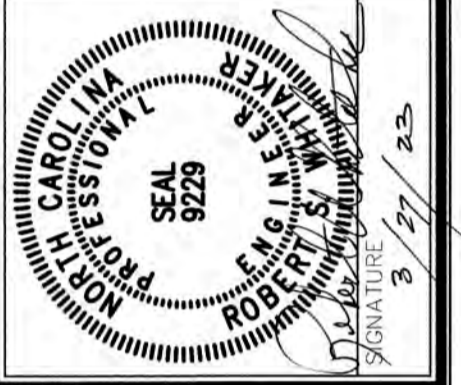

CONSTRUCTION NOTES AND CERTIFICATION STATEMENTS

DATE: MAR. 2022 SCALE: AS SHOWN

ADVANCED COMPOSTING TECHNOLOGIES
 P.O. Box 2440
 Candler, North Carolina 28715

20'x15' COLLECTION BUILDING HENDERSON COUNTY

N.B. NO.	SHEET
	7
PROJECT NO.	OF
05530	7

FILE: HendersonCounty-CollBlid

N:\PROJECTS\05530\DWG\HENDERSONCOUNTY-COLLECTIONBLDG-HENDERSONCOUNTY-COLLBLID.DWG 3/27/2023 3:18:05 PM

DESIGN CERTIFICATION STATEMENT

To the best of my professional knowledge, judgement and belief, these plans for **Henderson County** meet applicable state and local regulations.

Signed: Robert Whitaker
 Dated: 3/27/23

CONSTRUCTION CERTIFICATION STATEMENT

To the best of my knowledge, and belief, based upon a final inspection, the compost facility for **Henderson County** has been constructed in accordance with these plans (sheets 1, 2, 3, 4, 5, 6 & 7) for **ADVANCED COMPOSTING TECHNOLOGIES**.

Signed: _____
 Dated: _____

Attachment II: Vendor Information Form

Company/Firm Name

Mailing Address

Contact Name

Contact Title

Phone Number

Fax

Email

Website

Federal Tax ID Number

Unique Entity Identification Number (SAM.gov)

Required Documentation

Internal Routing

Completed IRS W-9 form dated within calendar year and signed by authorized personnel.

W9 Received

YES

Minority and Women Owned Business (MWBE) certification, if applicable.

MWBE Certification Received

YES

N/A

Unique Entity Identification Number
confirmed in SAM.gov

YES